

1 EU - TYPE EXAMINATION CERTIFICATE

2 Product or Protective System Intended for use in Potentially Explosive Atmospheres Directive 2014/34/EU – Annex III

3 EU - Type Examination Certificate No.: **TRL08ATEX11184X (incorporating variations V1 to V6)**

4 Product: **Flashlight / Head Torch, Model 2690**

5 Manufacturer: **Pelican Products Inc.**

6 Address: **23215 Early Avenue, Torrance, CA 90505, United States of America**

7 This product and any acceptable variation thereto is specified in the schedule to this certificate and the documents therein referred to.

8 Element Materials Technology, Notified Body number 2812, in accordance with Article 17 of Directive 2014/34/EU of the European Parliament and of the Council, dated 26 February 2014, certifies that this product has been found to comply with the Essential Health and Safety Requirements relating to the design and construction of products intended for use in potentially explosive atmospheres given in Annex II to the Directive. The examination and test results are recorded in the confidential report **XU1672/8972, TES-002696-33-00A, TRA-007514-33-00A, TRA-007967-33-00A, TRA-023773-33-00A and TRA-043218-33-00A**

9 Compliance with the Essential Health and Safety Requirements has been assured by compliance with:

EN 60079-0:2012+A11:2013 EN 60079-11:2012 EN 60079-26:2007
EN 50303:2000

Except in respect of those requirements listed at section 18 of the schedule.

10 If the sign "X" is placed after the certificate number, it indicates that the product is subject to specific conditions of use specified in the schedule to this certificate.

11 This EU - TYPE EXAMINATION CERTIFICATE relates only to the design and construction of the specified product. Further requirements of the Directive apply to the manufacturing process and supply of this product. These are not covered by this certificate.

12 The marking of this product shall include the following:

 **I M1 Ex ia I Ma**

II 1G Ex ia IIC T4 Ga

II 1D Ex ia IIIC T65°C Da

This certificate and its schedules may only be reproduced in its entirety and without change. This certificate is issued in accordance with the Element Materials Technology Ex Certification Scheme.

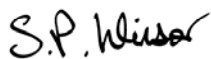

S P Winsor, Certification Manager

Issue date: 2019-11-01

Page 1 of 5

CSF355-NL 1.0

13 SCHEDULE TO EU - TYPE EXAMINATION CERTIFICATE

14 CERTIFICATE NUMBER TRL08ATEX11184X (incorporating variations V1 to V6)

15 Description of Product

The flashlight, model 2690 is a portable alkaline battery powered head torch. The unit comprises a PCB with various components and one LED, a reflector, and a battery compartment all contained within a main enclosure constructed of plastic with a clear plastic lens.

The flashlight must only be powered by three Panasonic, PN LR03 (Xtreme Power), Duracell, PN MN2400, or Energizer, PN E92 "AAA size" alkaline batteries.

The unit has an environmental ingress protection rating of IP65.

16 Test report No. (associated with this certificate issue): N/A

17 Specific Conditions of Use

1. This equipment may only be used with three cells of the following:-
 - a. Panasonic, PN LR03 (Xtreme Power)
 - b. Duracell, PN MN2400
 - c. Energizer, PN E92
2. Old batteries and new batteries shall not be mixed.
3. Battery compartment must only be opened in an area known to be non-hazardous and batteries may only be changed in a non-hazardous area.
4. The battery compartment must be secured by both screws.



Attention is drawn to the operating and installation instructions which may contain useful information in relation to conditions of use.

18 Essential Health and Safety Requirements (Directive Annex II)

In addition to the Essential Health and Safety Requirements covered by the standards listed at item 9, all other requirements are demonstrated in the relevant reports.

19 Drawings and Documents

The list of controlled technical documentation is given in Appendix A to this schedule.

20 Routine Tests

None.

21 Specific Conditions for Manufacture

1. The manufacturer shall inspect/verify the encapsulation around fuse (F1) does not contain voids/air bubbles and is at least 1mm thick in all dimensions around the fuse.

SCHEDULE TO EU - TYPE EXAMINATION CERTIFICATE

CERTIFICATE NUMBER TRL08ATEX11184X (incorporating variations V1 to V6)

22 Photographs



23 Details of Markings

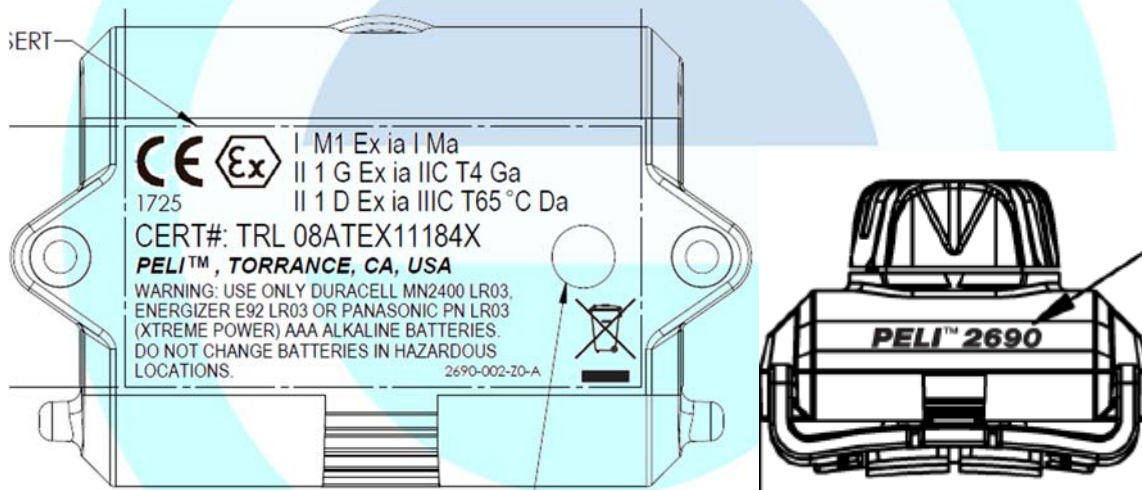

24 Details of Variations to this Certificate

This certificate is a consolidated certificate and reflects the latest status of the certification, including the following variations:

- Variation V1 – Update of drawings and marking plate.
- Variation V2 - Update of drawings.
- Variation V3 – Addition of mining classification and update of drawings.
- Variation V4 – Update to the latest standards: EN60079-0:2012; EN60079-11:2012; EN60079-26:2007. Additional change to the housing, head strap and foam pad materials and removal of Philips cell.
- Variation V5 - Lens material change, correction to resistor part number, spring contact material change, change to reflector material.
- Variation V6 - This certificate was originally issued by Notified Body number 0891 under Directive 2014/34/EU. The technical file has been transferred to Element Notified Body number 2812 without further assessment or evaluation.

SCHEDULE TO EU - TYPE EXAMINATION CERTIFICATE

CERTIFICATE NUMBER TRL08ATEX11184X (incorporating variations V1 to V6)

25 Notes to CE marking

In respect of CE Marking, Element Materials Technology accepts no responsibility for the compliance of the product against all applicable Directives in all applications.

26 Notes to this certificate

Element Materials Technology certification reference: NR-PCNQ-0001.

Throughout this certificate, the date format yyyy-mm-dd (year-month-day) is used.

Notified Body number 2812 is the designation for Element Materials Technology Rotterdam BV.

In accordance with Article 41 of Directive 2014/34/EU, EC-Type Examination Certificates referring to 94/9/EC that were in existence prior to the date of application of 2014/34/EU (20 April 2016) may be referenced as if they were issued in accordance with Directive 2014/34/EU. Variation certificates to such EC-Type Examination Certificates, and new issues of such certificates, may continue to bear the original certificate number issued prior to 20 April 2016.

27 Conditions for the validity of this certificate

This certificate remains valid for so long as:

- (i) The equipment listed in section 4 is manufactured in accordance with the documents listed in Appendix A of this certificate.
- (ii) The standards listed in section 9 of this certificate continue to satisfy the Essential Health and Safety Requirements of Annex II of Directive 2014/34/EU and the generally acknowledged state of the art (e.g. as determined by the publishers of those standards).

SCHEDULE TO EU - TYPE EXAMINATION CERTIFICATE**CERTIFICATE NUMBER TRL08ATEX11184X (incorporating variations V1 to V6)****APPENDIX A - TECHNICAL DOCUMENTS**

Title:	Drawing No.:	Rev. Level:	Date:
LED Driver Assembly, 2690 (3 pages)	2690-030-021	E	2018-09-12
PCB, 2690 Driver	2690-030-006	D	2015-02-12
PCB, CREE LED 2690 (2 pages)	2693-340-001	C	2015-03-20
2690 Headsup Lite Assembly Peli (2 pages)	2690-030-CLRE-Z0	B	2018-09-12
Shroud + Lens Assembly	2690-030-037E	A	2015-04-06
Battery Contact Spring, 2690	2690-030-030	B	2018-09-12
LED Module Assembly, 2690	2690-030-026	C	2015-03-20
O-Ring, Battery Cover, 2690	2690-030-018	A	2015-03-20
O-Ring, Shroud 2690	2690-030-017	B	2015-03-20
Brass Press-in Insert M3 x 0.5 Internal Thread	2690-030-016	B	2014-09-22
Battery Contact Dual, 2690	2690-030-013	B	2018-09-12
Battery Contact Spring, 2690	2690-030-012	B	2018-09-12
Battery Contact Dual, 2690	2690-030-011	B	2018-09-12
Contact Spring, LED Driver, 2690	2690-030-010	C	2018-09-12
Contact Spring, LED Module, 2690	2690-030-009	D	2018-09-12
Reflector 17mm, 2690	2690-030-008	C	2018-09-12
Battery Tray, 2690	2690-030-005	B	2014-09-22
Bracket, 2690	2690-030-003E	A	2015-04-06
Cover, battery 2690	2690-030-002E	A	2015-04-06
Housing, 2690 (2 pages)	2690-030-001E	A	2015-04-06
PCB + LED Assembly, 2690	2693-340-000	E	2015-03-20
Shroud Overmold Lens, 2690	2690-030-004E	B	2018-09-12
HeadsUp Lite 2690 Zone 0 – Instructions	2693-319-506	B	2019
Peli 2690 approval insert	2690-002-Z0	A	2015-01-29
Peli head strap cloth, 2690	2690-030-039E	A	2014-04-21
Head strap rubber, 2690	2690-030-020E	A	2015-04-21
Foam pad, 2690	2690-030-035	B	2014-04-06
2690 PCB CREE XP LED	2693-340-002	A	2011-12-01