

ATEX/IECEX LED Mini Worklite™ WL-50 - NEW 2020

Zones: 1, 2, 21 and 22



Product Overview

The ATEX & IECEx certified WL-50 & WL-50HT light weight mini Worklite™ is an easily carried, rechargeable, high output LED floodlight for use in harsh, remote, hazardous area applications.

At just over 9kgs, it weighs around half the weight of the WL-80 and WL-85 worklites, and provides the same outstanding level of light.

Building on the success of our market leading Worklites and Floodlites, the WL-50 shares the same strong, robust and proven powder coated die-cast construction as the WF-300XL and WF-250XL.

It is CE marked to the ATEX Directive for safe use in Zones 1, 2, 21 and 22 potentially explosive gas, vapour, mist and dust atmospheres, where a T4 temperature class permits.

- Light output - up to 3,100 lumens at source
- Light Duration - up to 10 hours
- Light weight - just over 9kgs
- LED Life - designed to give 100,000+ hours
- ATEX & IECEx Certified

The WL-50 & WL-50HT have an 18 LED lamp head which gives over 3100 lumens output at source from the small, lightweight battery. It delivers a piercing spot beam and a flood of lower level fringe light. The LED light source is designed to give over 100,000 hours life.

Battery duration is up to 5 hours on 'high power' and up to 10 hours on 'low power'. In addition to dual light output levels, the control circuit manages the switch function, battery level indicator and the low battery cut-off, maintaining and protecting the battery from deep discharge damage.

The painted powder coated aluminium construction is designed to

Features & Benefits

- **Certification:**
 - ATEX and IECEx Approved for Zone 1/21 explosive gas and dust atmospheres, and OP IS compliant
 - IP Rating: certified to both IP66 and 67, the Worklite™ is dust tight and protected against powerful water jets and immersion up to 1 metre
 - Ambient approved:
 - -20°C to +45°C - WL-50
 - -20°C to +50°C - WL-50HT
 - ATEX certified anti-static protective lens guards and paint protection covers available
- **Light output:**
 - 3,100 lumens at source
 - High power white LED piercing spot beam with flood of lower level fringe light
 - LED light source 'fitted for life' with 100,000+ hours life.
- **Light duration:**
 - Up to 5 hours full power
 - Up to 10 hours half power
- **Features:**
 - Robust and durable aluminium construction
 - Toughened glass lens with optional disposable lens guard
 - 2 power levels
 - Adjustable angle in frame
 - Rechargeable high capacity battery, fully managed
 - State of charge LED indication
 - Supplied with a mains charger with state of charge indication, powered from 100 to 254Vac
 - Compatible with Wolf tripods and Magnetic Bracket kits
 - Certified anti-static protection kits available

withstand the rigours and corrosion of harsh industrial and offshore applications.

Mounted in a stainless steel stand, the battery light source and control circuit are within the enclosure giving IP66 and IP67 protection from ingress of dust and water – so as well as being "dust tight," the Worklite™ is protected against powerful jets of water and immersion up to a depth of 1 metre.

The stainless steel stand offers additional protection and allows you to easily direct the light to exactly where it's needed. The lamp can also be used on tripods or attached to flat ferrous metal surfaces with magnet bracket kits for complete flexibility in getting the light to just where you want it.

The lens is impact resistant 6mm toughened glass. For shot blasting and painting applications, the lens can be protected by an ATEX certified disposable antistatic lens guard and in paint applications an ATEX certified antistatic protection cover (1 supplied) is available to protect the light.

Should it ever be required, the battery, circuit and LED can be replaced by a suitably qualified technician.

Certifications



Technical Specification

Product Reference		WL-50	WL-50HT
Product Description		High Power Rechargeable Battery Worklite™	
Code		II 2 GD Ex e ib mb op is IIC T4 Gb Ex tb op is IIIC T135°C Db	
Type of Protection		'e' Increased Safety, 'ib' Intrinsic Safety, 'op is' optical intrinsic safety, 'mb' Encapsulation, tb Enclosure Protection	
Area of Classification (Gas)		Zones 1 and 2, Gas Groups IIA, IIB, IIC	
Temp. Classification (Gas)		T4	
Area of Classification (Dust)		Zones 21 and 22, Dust Groups IIIA, IIIB, IIIC	
Max Surface Temp. (Dust)		T135°C	
Ambient Temperature		-20°C to +45°C	-20°C to +50°C
Certificate		CML 18ATEX3373X, IECEx CML 18.0199X	
Enclosure		Die Cast Aluminium	
Lens		Toughened Glass Lens	
Beam Type		Spot Beam with a Flood of Low Level Fringe Light	
Light Source:	Type	High Power LED	
	Power / Output	18 x High Power LEDs / Up to 3100 lm at source	
	Life	100,000hrs+ (Fitted for Life)	
Power Source:	Part No.	W-3200	W-3300
	Battery Type	Rechargeable Battery, Sealed Gel Lead Acid	
	Volts	12V	
	Capacity	10Ah	9Ah
	Life	Up to 200 Recharge Cycles#	
Low Battery Indicator		Yes	
Light Duration - High		Up to 5hrs / 10hrs	Up to 4.5hrs / 9hrs

/ Low	
Ingress Protection	IP66 and IP67* to IEC60529
Weight (inc. battery)	9.3kg
Charger Input	100 - 254 Vac
Recharge Time	8hrs

Cycle life is dependent on ambient temperature. In a 20°C ambient the cycle will be about 200 full cycles, it will be fewer at higher temperature ambients

* Being certified to both IP66 and IP67, the Worklite™ is "dust tight" and protects against powerful water jets and immersion up to 1 metre

- All information has been gathered under laboratory conditions, the user must regard the values given as approximate.
- Changes may be made to the above specification without notification, details are available on request.

Product Dimensions

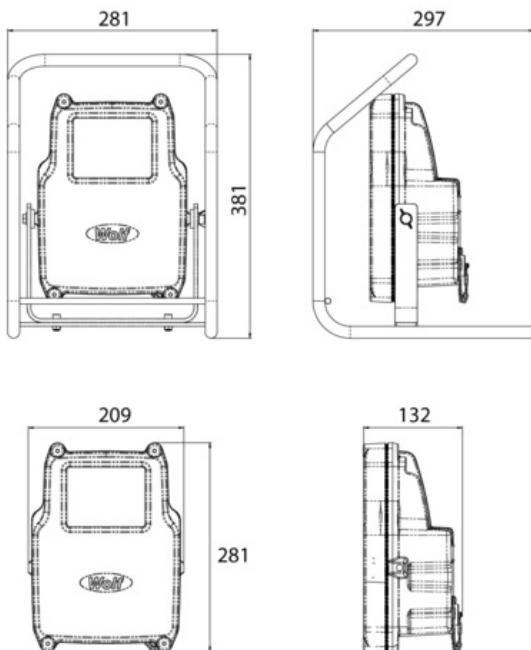

Light Output

Spot Beam, approximately 14°, with a flood of lower level fringe light.

Full Power:

14,146 Lux at 1m

566 Lux at 5m

Half Power:

7,455 Lux at 1m

298 Lux at 5m

